

Gas Transport and Control in Thick-Liquid Target Chambers and Heavy-Ion Beam Lines: Past, Present, Future

Christophe S. Debonnel

**Thermal Hydraulics Laboratory
Department of Nuclear Engineering
University of California, Berkeley**

**Lawrence Berkeley National Laboratory
Heavy-Ion Inertial Fusion Virtual National
Laboratory**

**ARIES Meeting
Princeton, October 2, 2002**

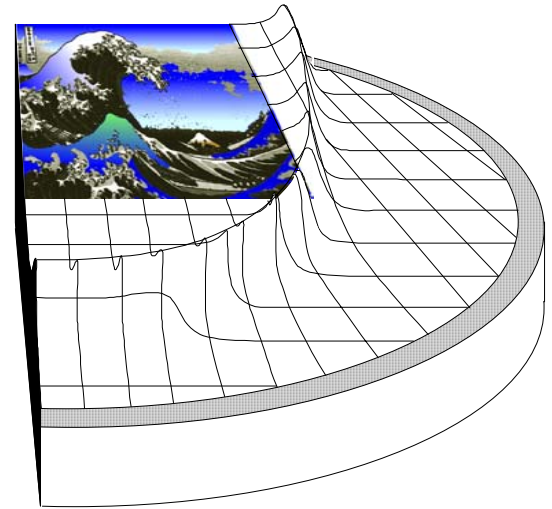

Key heavy-ion thick-liquid chambers phenomena include gas dynamics and vapor condensation in the target chamber and in the beam tubes

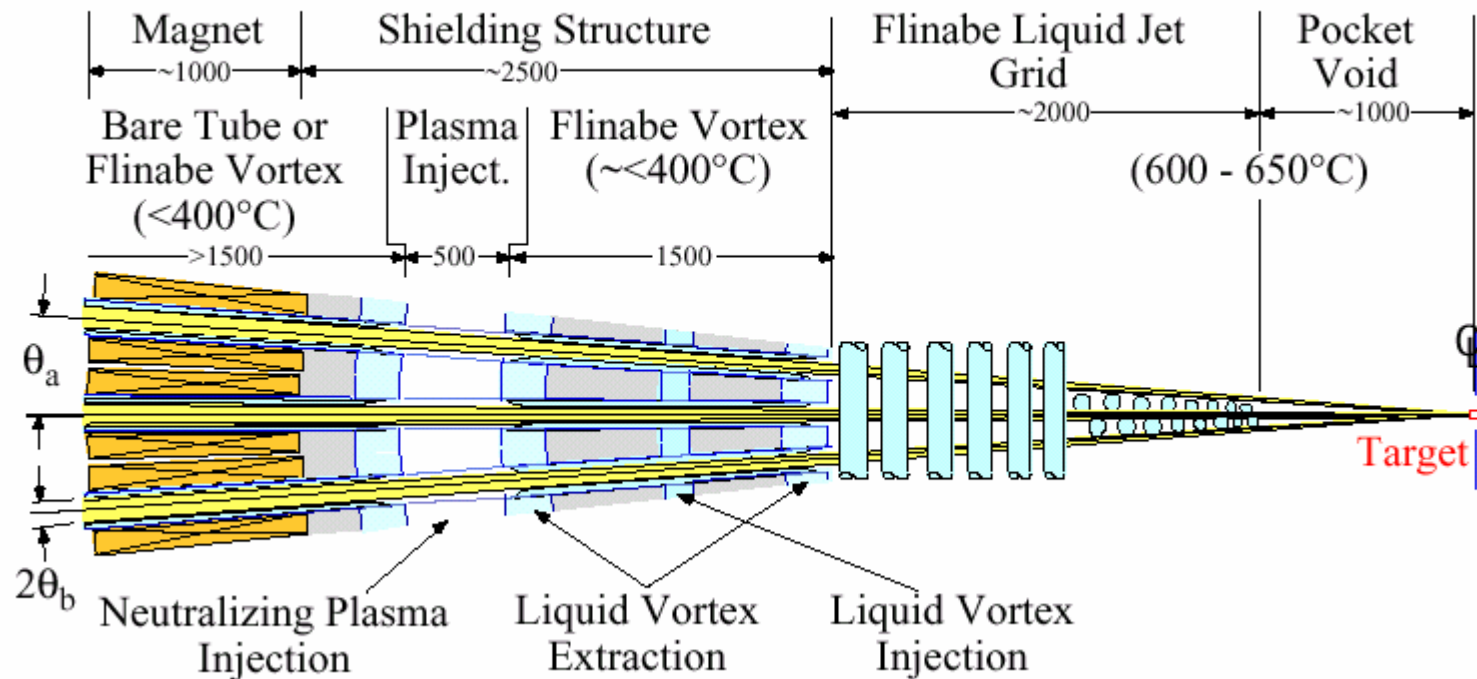

Outline

- **What has been known for some time:**
 - **Beam Tube: Issues and Early Treatment**
 - **Target Chamber Modelling and the various TSUNAMI Codes**
- **What has been investigated recently (2000-2002):**
 - **A New Beam Tube Design**
 - **The current TSUNAMI code**
- **What will/should be known:**
 - **Beam Tube and Target Chamber Engineering & Physics**
 - **The future of TSUNAMI**

80's: HIBALL-II Report

- Many of beam tubes issues identified. Clearing time estimates.
- *Effect of Cavity Atmosphere on the Beam Lines*
 - Rotating Shutters? No.
 - *If the beam duct wall temperature can be carefully controlled such that the condensed vapor runs off in the liquid form and is returned to the cavity, then accumulation ceases to be a problem.*
 - *With a sticking coefficient of unity on the beam duct walls, the vapor does not develop a boundary layer and there are no viscous effects from the walls. Using molecular flow theory, it is evident that the expanding vapor which enters the beam port is immediately condensed on the walls. It can be shown that the pressure can fall two orders of magnitude per meter of beam line if the narrow dimension of the beam line is < 40 cm.*

90's: The various TSUNAMI Codes

- **TranSient Upwind Numerical Analysis Method for Inertial confinement fusion**
- **Provides estimates of the gas dynamics behavior during the venting process in inertial confinement energy systems**
- **Solves Euler's equations for compressible flows**
- **Various ablation and target models.**

90's: The various TSUNAMI Codes

- **Chen et al: 1-D, radiation, real gas equation, studied venting inside the pocket**
- **Liu et al: 2-D, ideal gas, studied venting through the pocket**
- **Liu et al: 1-D, ideal gas, condensation**
- **Scott et al: 2-D, multi-species, SESAME EOS, ABLATOR, studied mini-chamber for NIF**
- **Jantzen et al: 2-D, new EOS, radiation, studied various venting through various pocket geometries**

Early 00's: Cut-away view shows beam and target injection paths

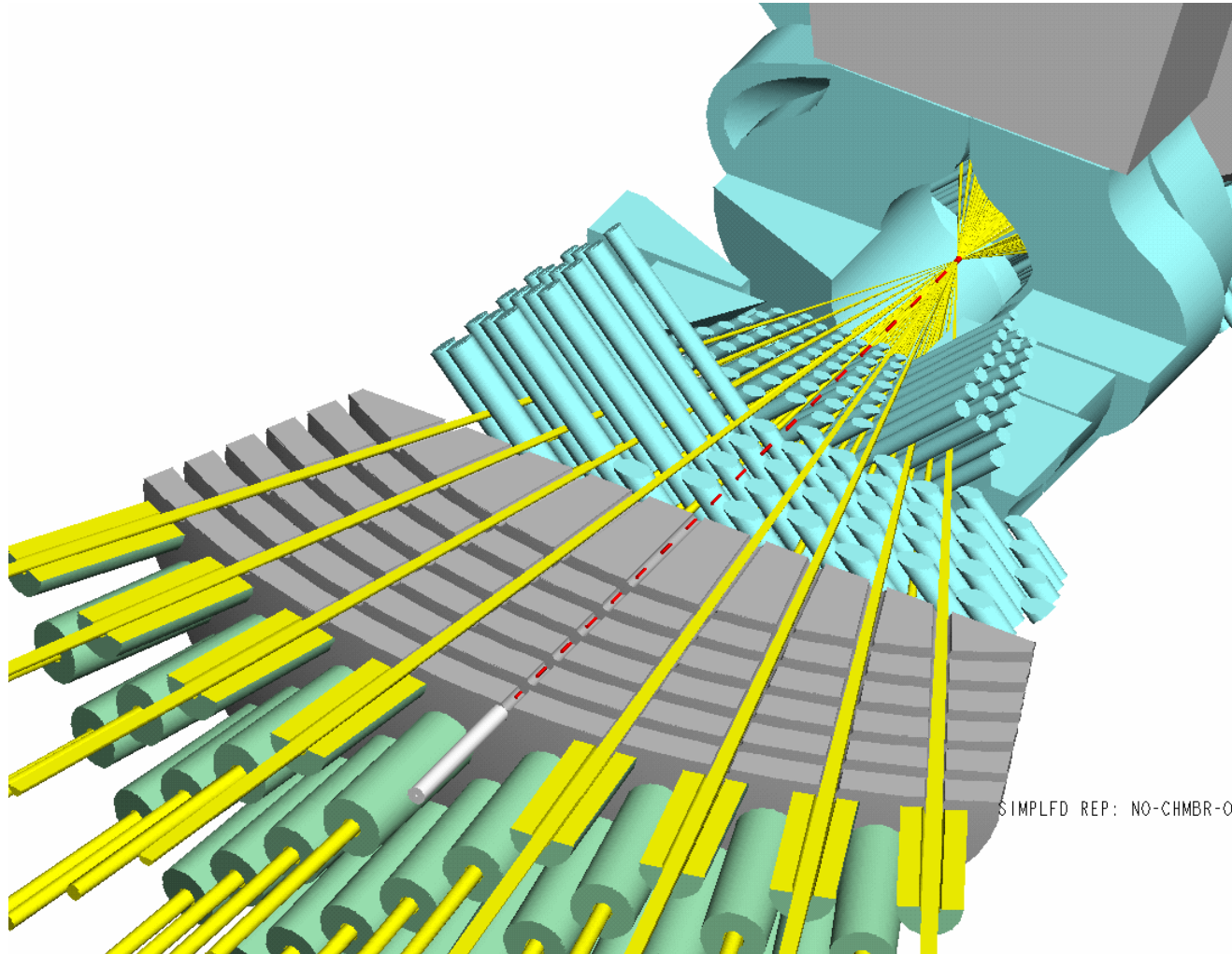

All of the liquid configurations needed for HIF chambers have been demonstrated in scaled experiments

Crossing cylindrical jets form beam ports

Oscillating jets form main pocket

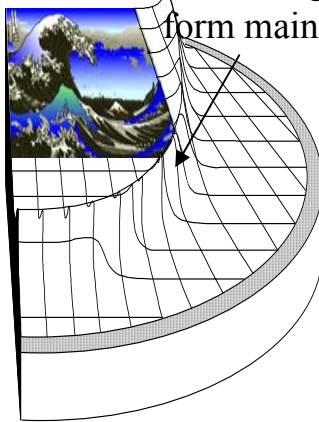

Vortices shield beam line penetrations

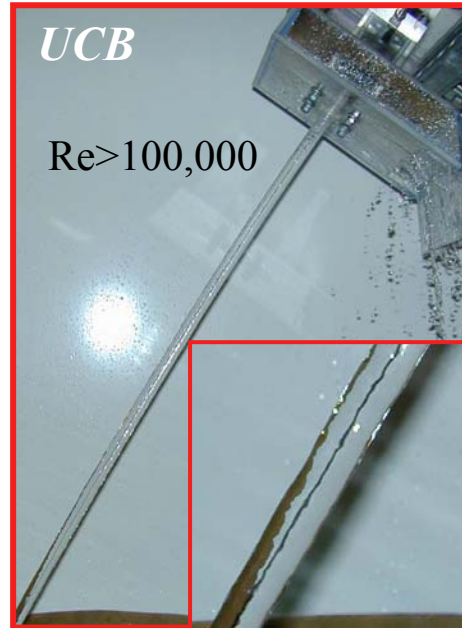

Highly smooth cylindrical jets

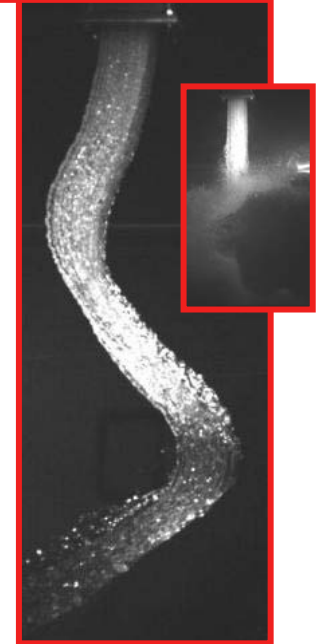

Slab jet arrays with disruptions

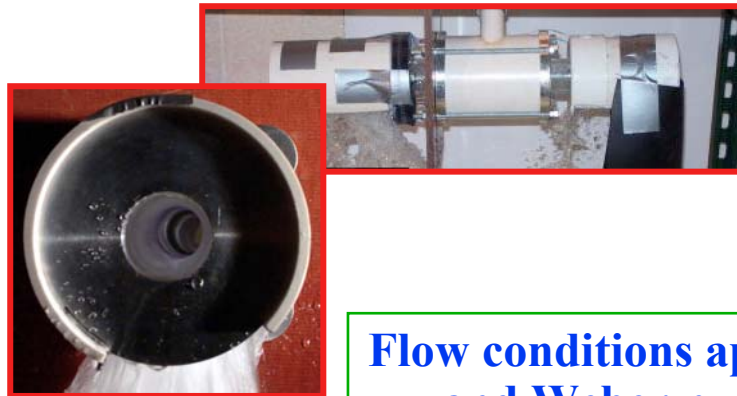

Vortices

Flow conditions approach correct Reynolds and Weber numbers for HYLIFE-II

Strategies to Prevent Debris Deposition in the Beam Tubes (2000-2001)

- Design efficient target chamber structures
- Mass and energy fluxes at the entrance of beam ports should be as low as possible
- Debris should be vent towards condensing areas
- Venting in target chamber has been modeled to determine inlet boundary conditions for the beam tubes
- Debonnel et al., *Control of the heavy-ion beam line gas pressure and density in the HYLIFE thick-liquid chamber*, FE&D, in press

The TSUNAMI 2.8.3 Code

- **TranSient Upwind Numerical Analysis Method for Inertial confinement fusion**
 - **Solves Euler's equations for compressible flows**
 - **Real gas equation**
 - **Two-dimensional, axially symmetric pocket**
 - **Reflective or open boundary conditions**
 - **Ablation model**

Axially symmetric 9x9 – Density Contour Plots

Density at 1e-006 s [kg m^{-3} , log scale] Density at 3e-006 s [kg m^{-3} , log scale]

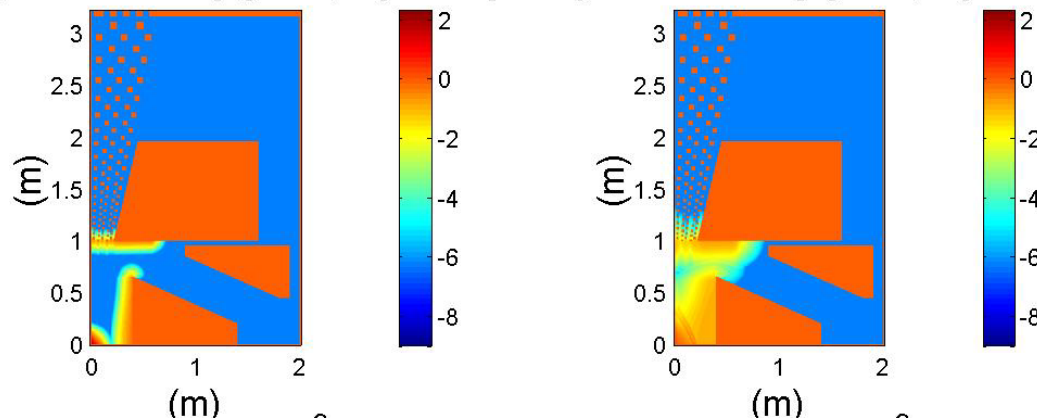

Density at 9e-006 s [kg m^{-3} , log scale] Density at 3e-005 s [kg m^{-3} , log scale]

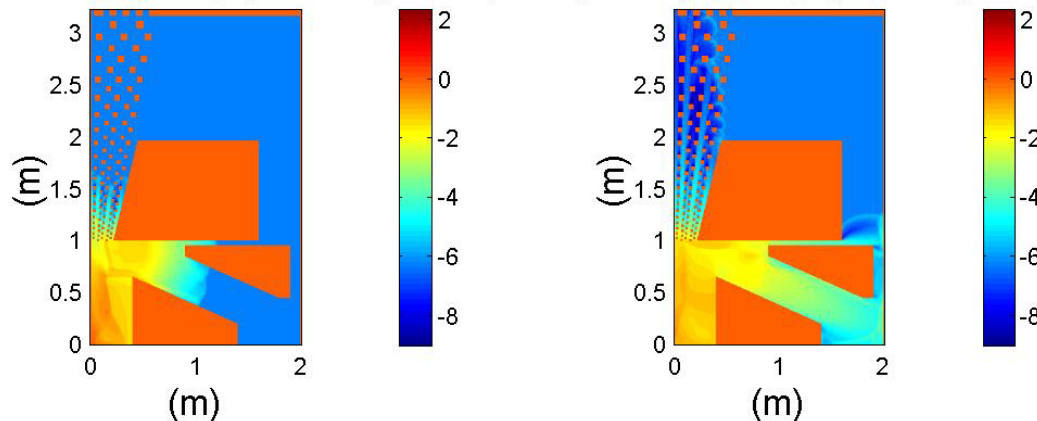

Fukuda (UCB) has identified a new salt composition allowing lower pressures

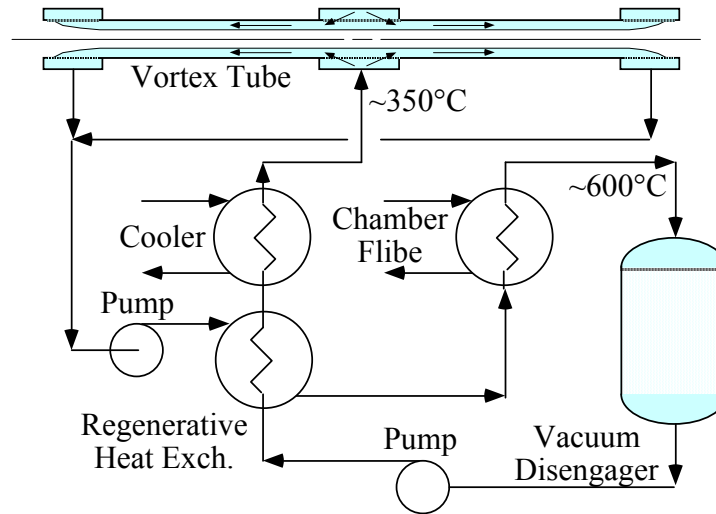

A degassing system may permit flinabe to be used for He/H₂ pumping

- Ternary salt systems (“Flinabe,” LiF/NaF/BeF₂) have been identified with very low melting temperatures (320°C)
 - Equilibrium vapor pressure (10⁹/cc at 400°C)
 - Debonnel et al., *Control of the heavy-ion beam line gas pressure and density in the HYLIFE thick-liquid chamber*, FE&D, in press

Strategies to Prevent Debris Deposition in the Beam Tubes (2002)

- **New motivation: Breakdown voltage**
- **Liquid Vortex**
- **Mechanical shutters too slow**
- **Magnetic Shutters**
- **Debonnel et al., *Gas Transport and Density Control in the HYLIFE Heavy-Ion Beam Lines*, submitted to FS&T**

Vortex Tubes

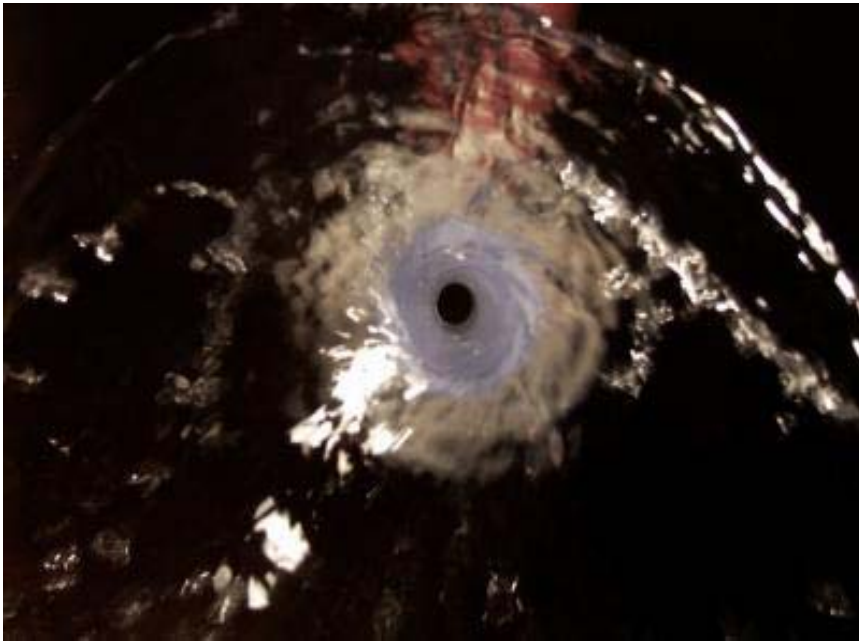

- Annular flow in the beam tubes can reduce the apertures in the square lattice to round ports called “Vortex Tubes”
- Stable centrifugal flow provides additional protection in the beam lines

Vortex Layer Construction



- Formation of the vortex layer requires injection of liquid tangent to the inner pipe wall, directed at some angle θ from the pipe axis
- An outer flow plenum and an inner wall with many small, properly aligned injection holes provides a good tube
- Pemberton et al., *Annular Vortex Generation for IFE Beam Line Protection*, submitted to FS&T

A few questions raised last time...

- What about flibe?
- Any end effect?
- Gravity?
- Not a cylindrical tube?
- Pumping power?

Beam Tubes – TSUNAMI Density Contour Plots

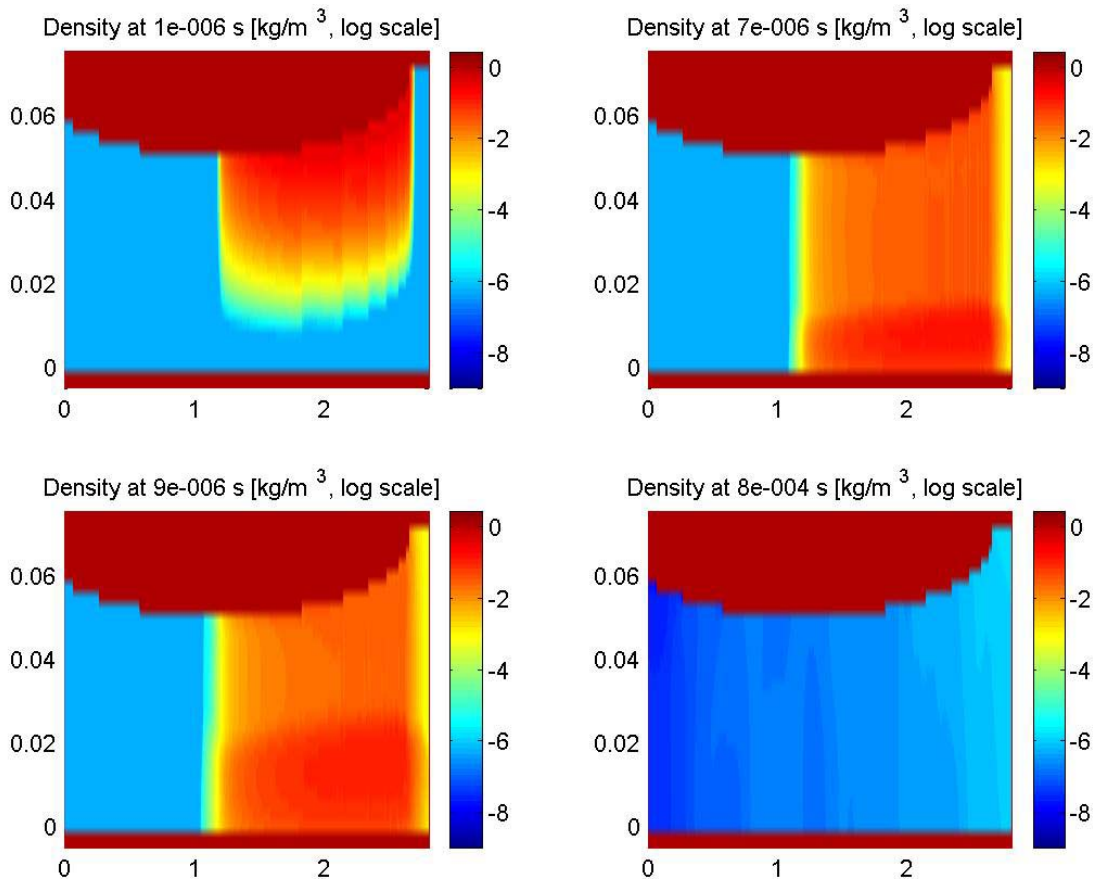

A plasma will be blown off the chamber target and expand into the beam port

- We expect the plasma to be of order 10^{14} cm⁻³ density and 10 eV
- Neutral fraction may be quite small for these conditions
- Plasma can be diverted to port wall with a vertical or dipole magnetic field

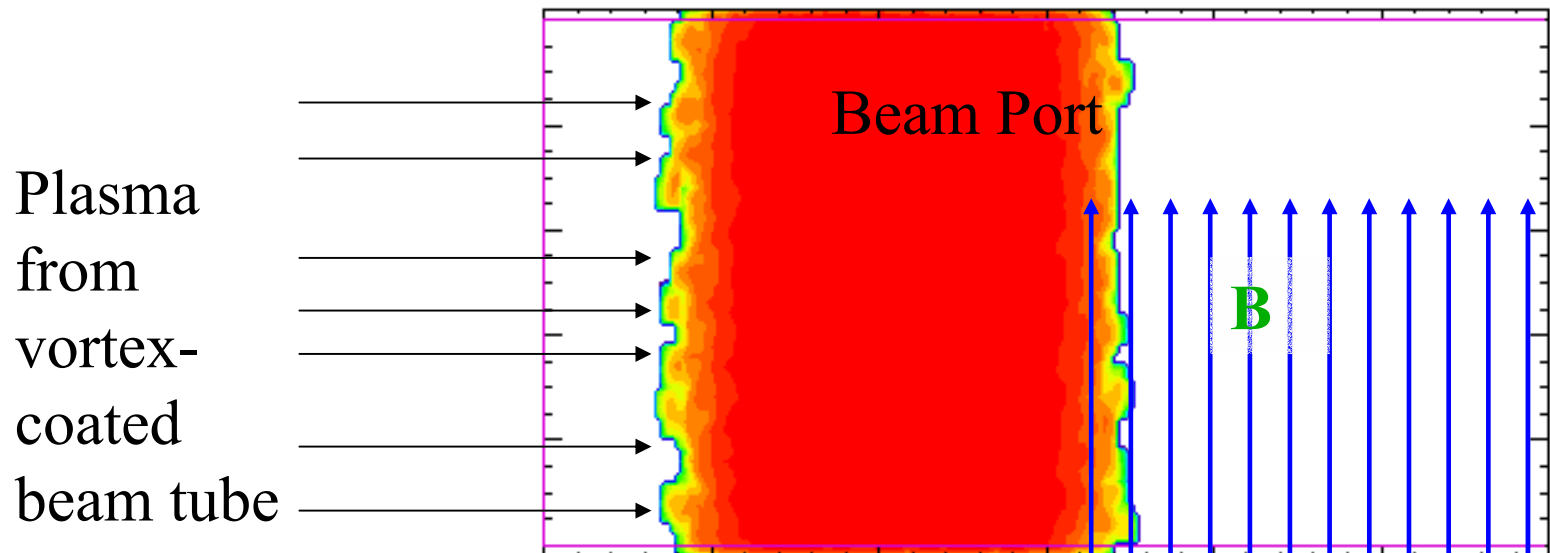

100-eV plasma with $v = 9 \text{ cm}/\mu\text{s}$; MRC's 2-D LSP results show plasma ion stagnation at $\sim 15.5 \text{ cm}$

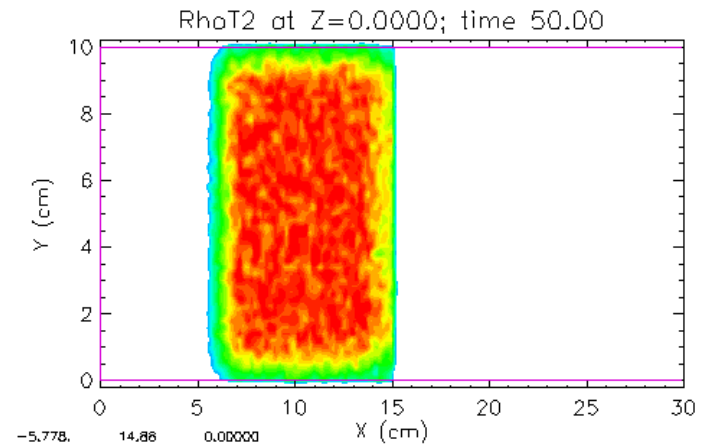
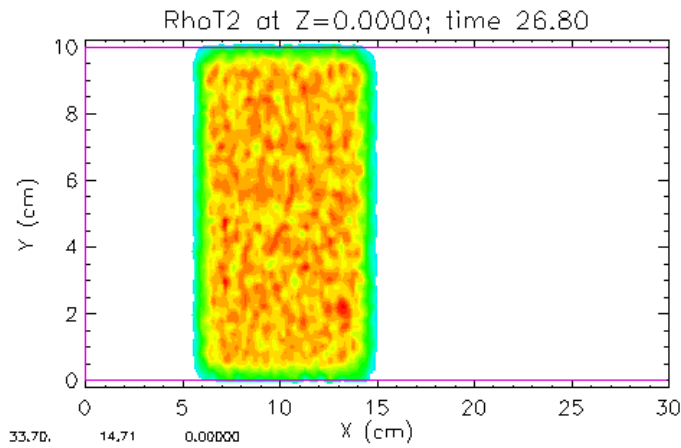

2D expansion with self fields and 1kg B: portp5.lsp - Tue Apr 9 14:44

Legend
 1.000E+01 2.2001E+013 3.902E+013 5.803E+013 7.704E+013 9.604E+013 1.151E+014
 5.752E+012 2.478E+013 4.377E+013 6.278E+013 8.179E+013 1.006E+014 1.198E+014
 1.050E+013 2.951E+013 4.852E+013 6.753E+013 8.654E+013 1.055E+014 1.248E+014
 1.526E+013 3.427E+013 5.327E+013 7.228E+013 9.129E+013 1.103E+014 1.293E+014

2D expansion with self fields and 1kg B: portp5.lsp - Tue Apr 9 14:44
 Legend

1.000E+012 2.014E+013 3.929E+013 5.843E+013 7.757E+013 9.671E+013 1.159E+014 1.350E+014
 5.786E+012 2.493E+013 4.407E+013 6.321E+013 8.236E+013 1.015E+014 1.208E+014
 1.057E+013 2.971E+013 4.886E+013 6.800E+013 8.714E+013 1.063E+014 1.254E+014
 1.536E+013 3.450E+013 5.364E+013 7.279E+013 9.193E+013 1.111E+014 1.302E+014

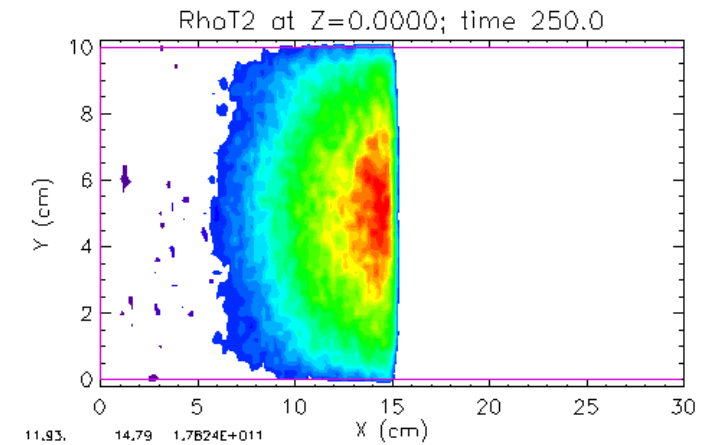
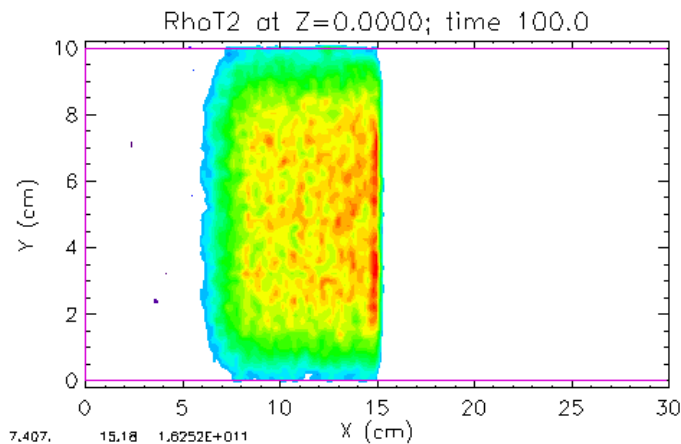

MRC's 3-D LSP Simulation of 10^{14} cm^{-3} , 100 eV,
 $v_{\text{drift}} = 9 \text{ cm}/\mu\text{s}$ case:

- 3-D simulations use same EM implicit field solver as 2-D case.
- Initial simulations use smaller beam port radius (2.5 cm) for computational efficiency
- Same plasma parameters as 2-D case.

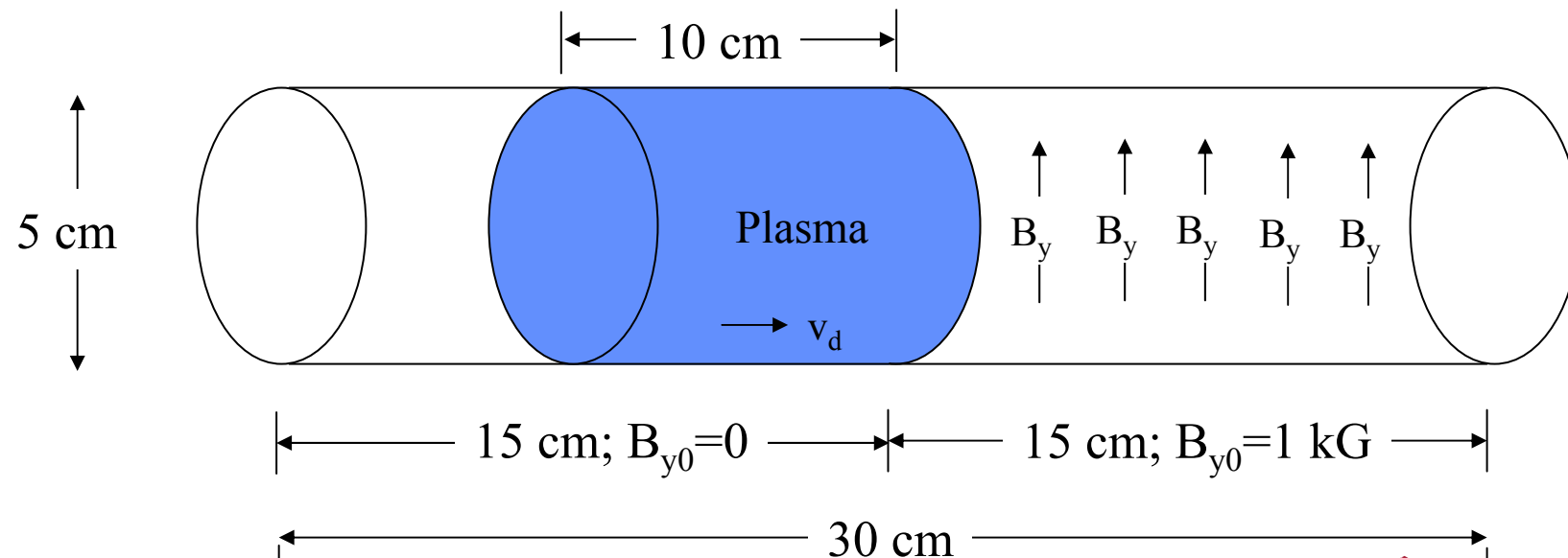

Test Case: Ion expansion without applied B_y -field...

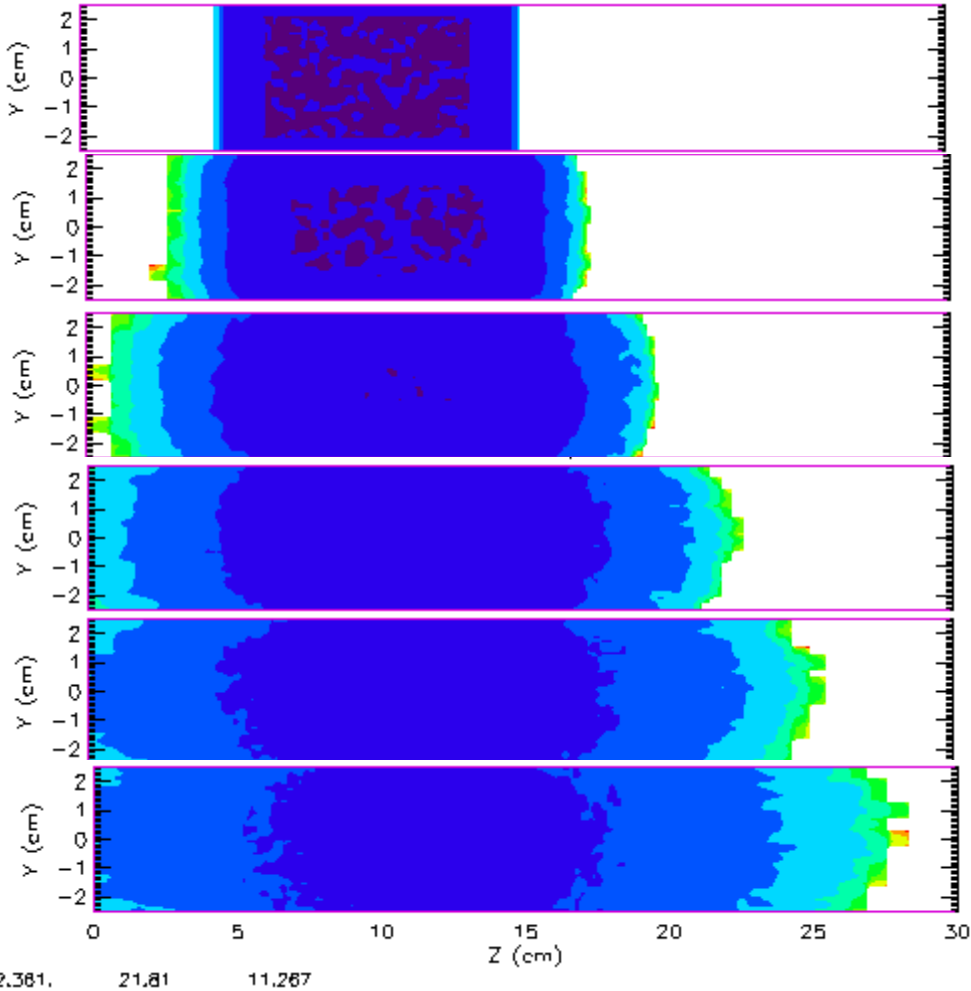

0 ns

50 ns

100 ns

150 ns

200 ns

250 ns

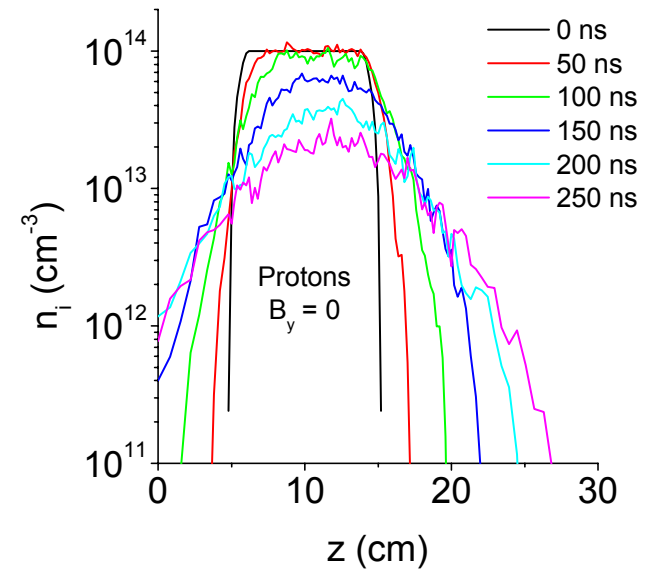

Greater ion expansion into applied B-field is observed in 3D case.

1 kG applied B_y field

$$V_{drift} = 9 \text{ cm}/\mu\text{s}$$

$$T_e = T_i = 100 \text{ eV}$$

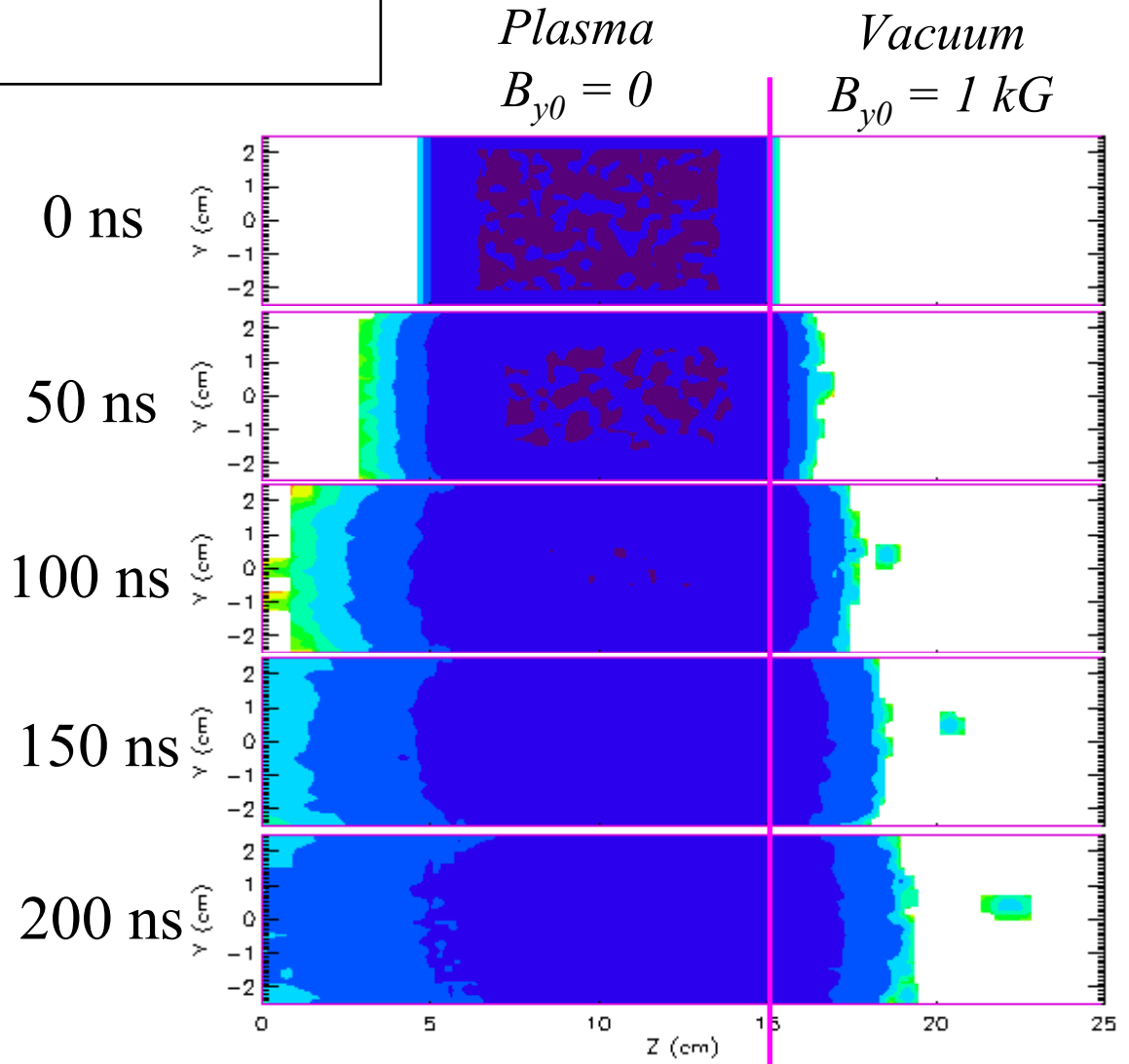
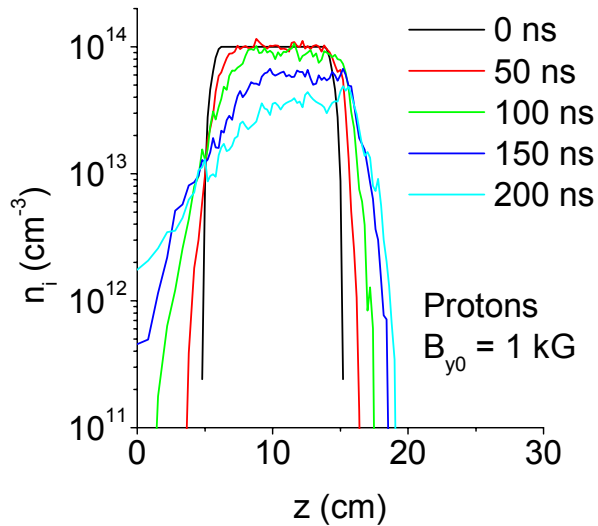

Future Work: Gas Transport in Target Chamber and Beam Lines

- Towards a (Robust) Point Design.
 - Recommendations for the pocket geometry and condensing area required.
 - Ionization state -> Ionization plasma
- Improving the Physics in TSUNAMI:
 - Revise ablation model
 - Condensation, Evaporation
 - Radiative Transport

Conclusions

- **TSUNAMI predictions indicate that thick-liquid structures in target chamber should be supplemented by other engineering devices in the beam tubes to prevent debris contamination in the final-focus magnet region.**
- **Beam tube can be coated with liquid vortex.**
- **Vaporized debris can be diverted by a moderate strength magnetic field, once ionized.**