

# *Interferometric In-Chamber Tracking*

Presented to:

Second U.S./Japan workshop on Target  
Fabrication, Injection and Tracking  
General Atomics, San Diego, CA

Presented by:

Dr. Ilya Agurok and Dr. Gajendra Savant  
Physical Optics Corporation  
Photonic Systems Division  
2545 W. 237<sup>th</sup> Street, Suite B  
Torrance, CA 90505

**February 2003**

# Interferometric in-chamber tracking system for Inertial Fusion Experiment

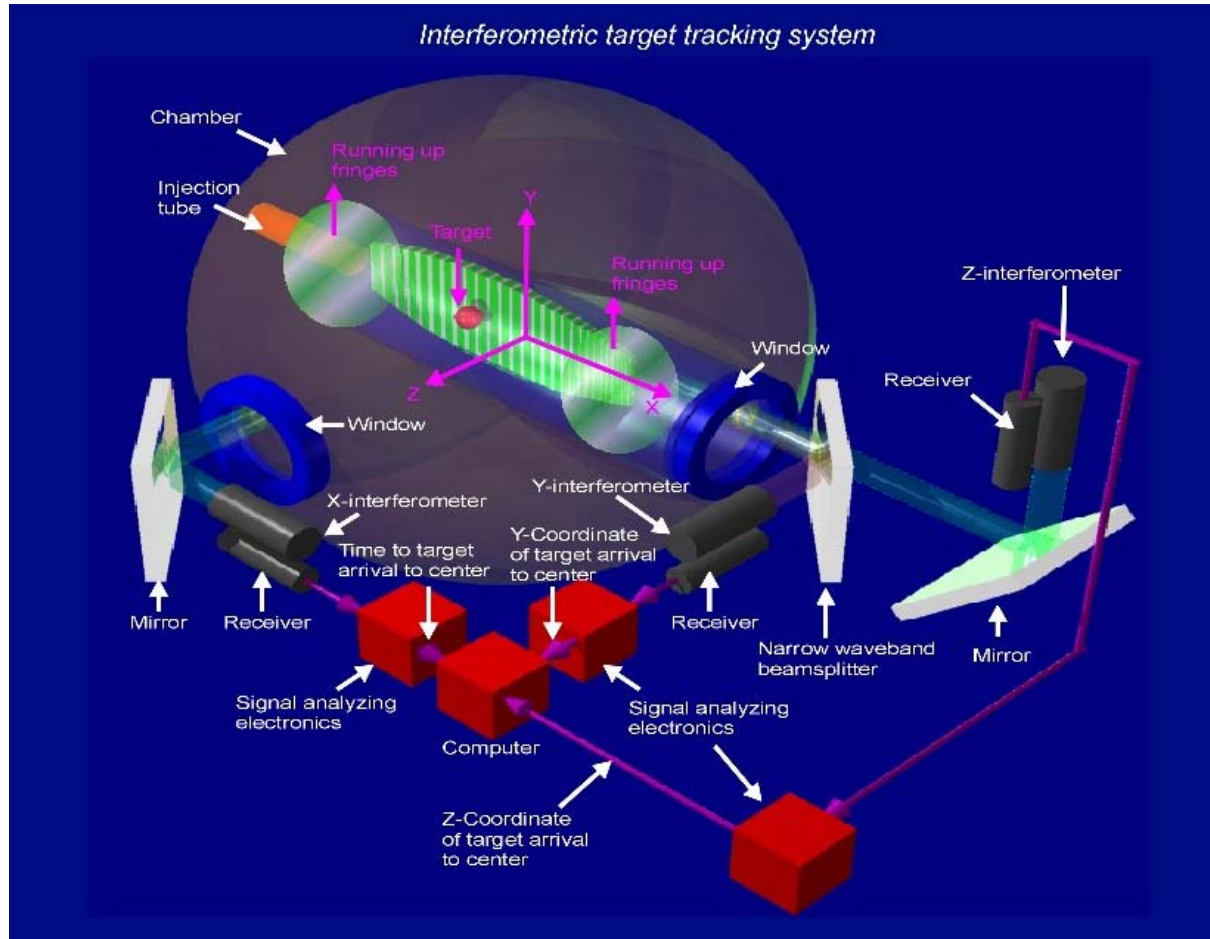

# Tracking along trajectory

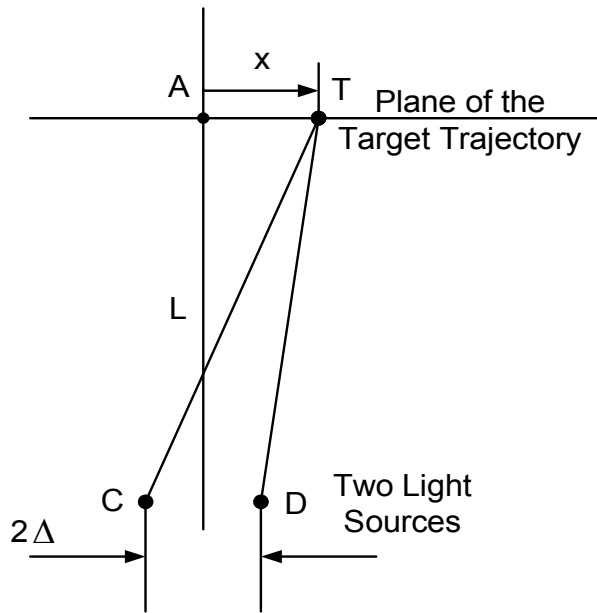

a) Optical path difference in the interference plane.

$$I = I_0 \left\{ 1 + \cos \left( \cos \frac{2\pi}{\lambda} \delta \right) \right\} \quad (1)$$

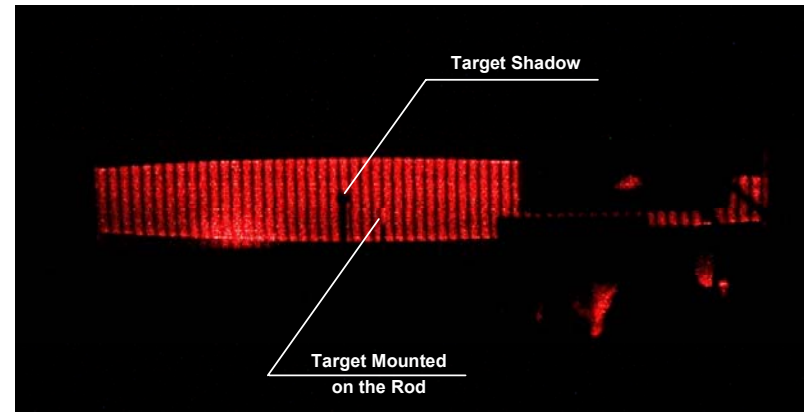

b) Pattern of interference fringes on screen behind target simulation translator (Phase I prototype).

$$\begin{aligned} \delta &= CT - DT = \sqrt{L^2 + (x + \Delta)^2} - \sqrt{L^2 + (x - \Delta)^2} \cong \\ &\cong 2\Delta x / \sqrt{L^2 + x^2} \end{aligned} \quad (2)$$

# Lose-free X-tracking interferometer

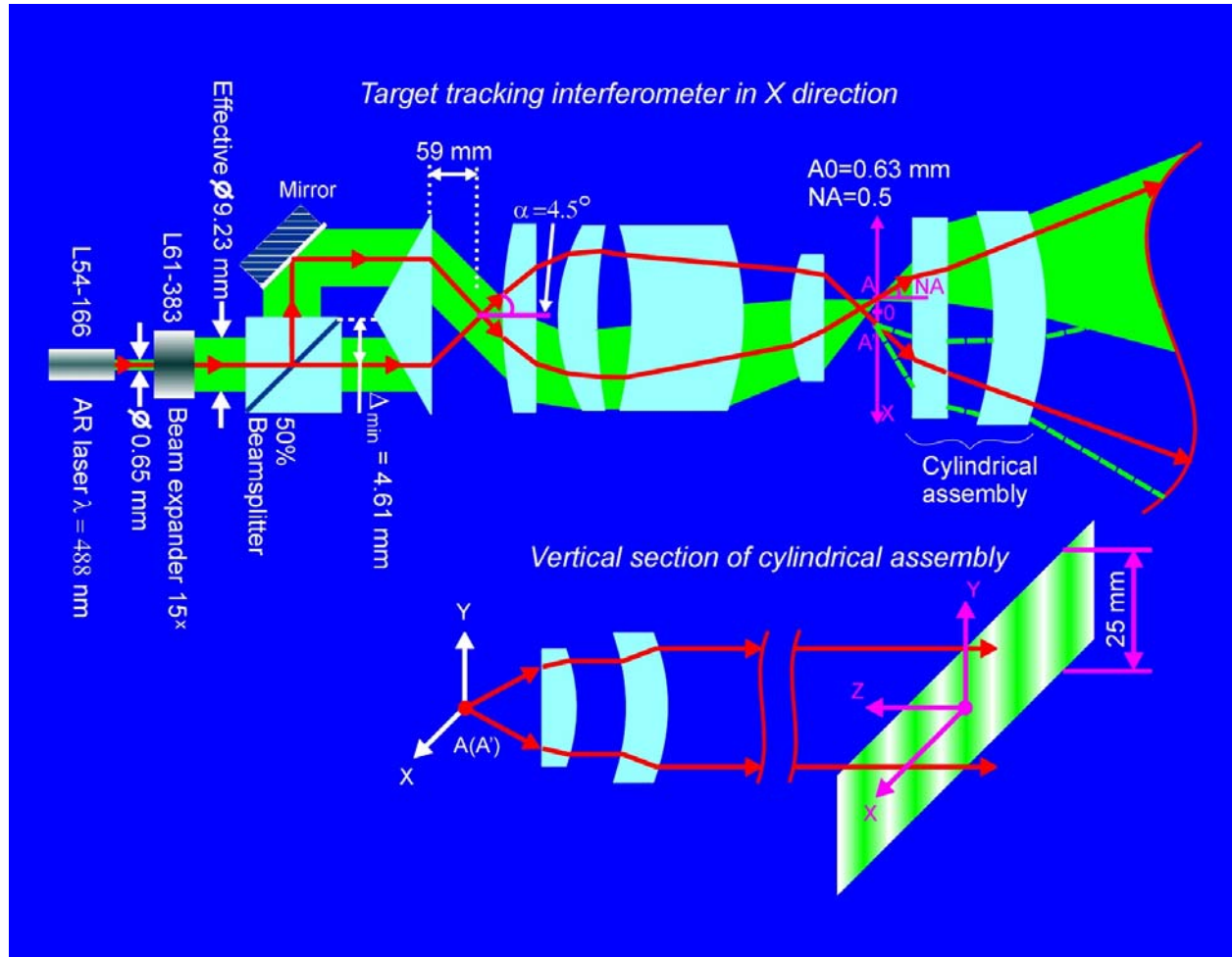

# *Focusing objective for the X-tracking interferometer*

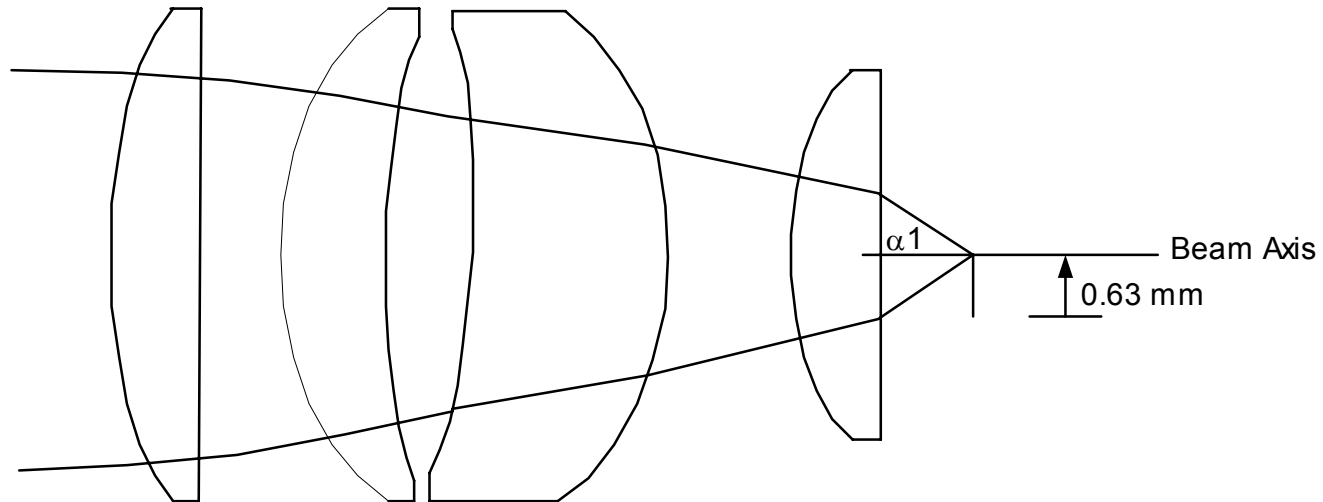

# Importance of the telecentric arrangement

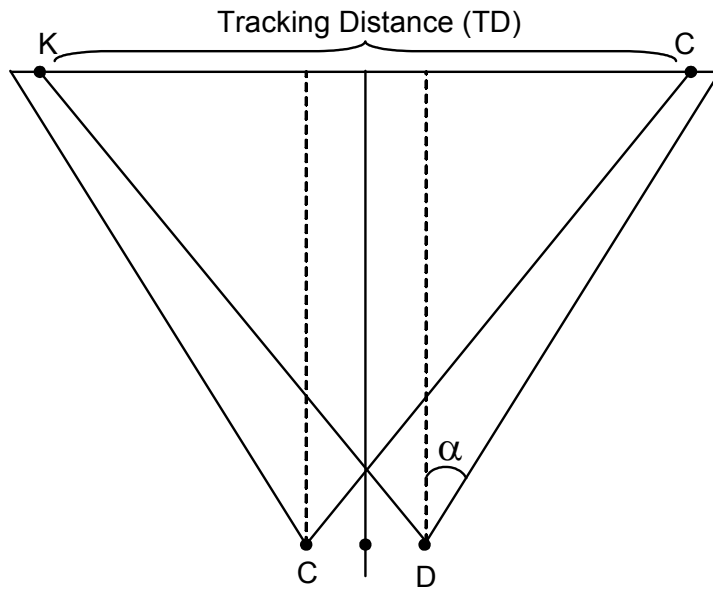

a) Telecentric arrangement

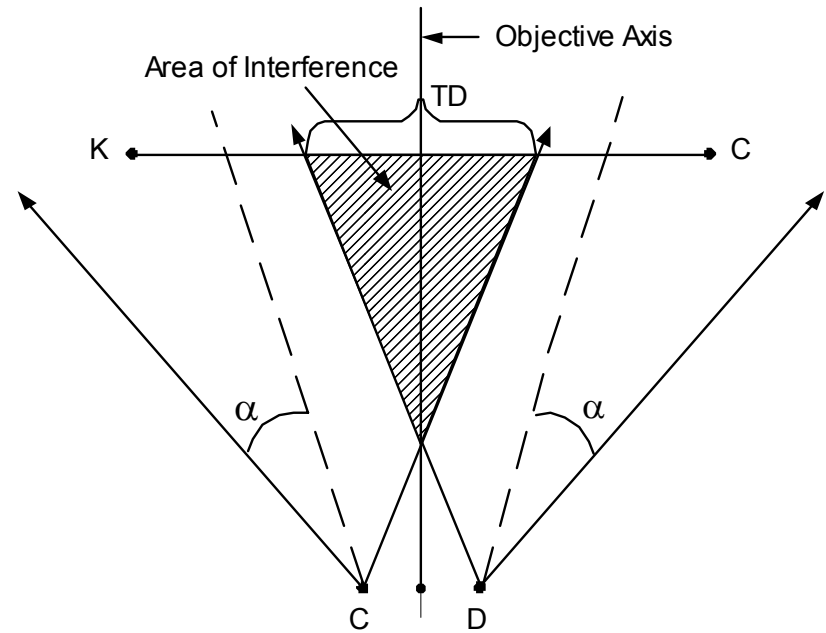

b) Beams axis inclined to the objective axis



# Wavefront deformation Zernike coefficients

Z	1	-0.005661 :	1
Z	2	0.000000 :	$(p) * \text{COS}(A)$
Z	3	0.005025 :	$(p) * \text{SIN}(A)$
Z	4	-0.000880 :	$(2p^2 - 1)$
Z	5	0.000299 :	$(p^2) * \text{COS}(2A)$
Z	6	-0.000000 :	$(p^2) * \text{SIN}(2A)$
Z	7	-0.000000 :	$(3p^2 - 2) p * \text{COS}(A)$
Z	8	-0.000088 :	$(3p^2 - 2) p * \text{SIN}(A)$
Z	9	-0.000120 :	$(6p^4 - 6p^2 + 1)$

# *Y, Z tracking interferometer*

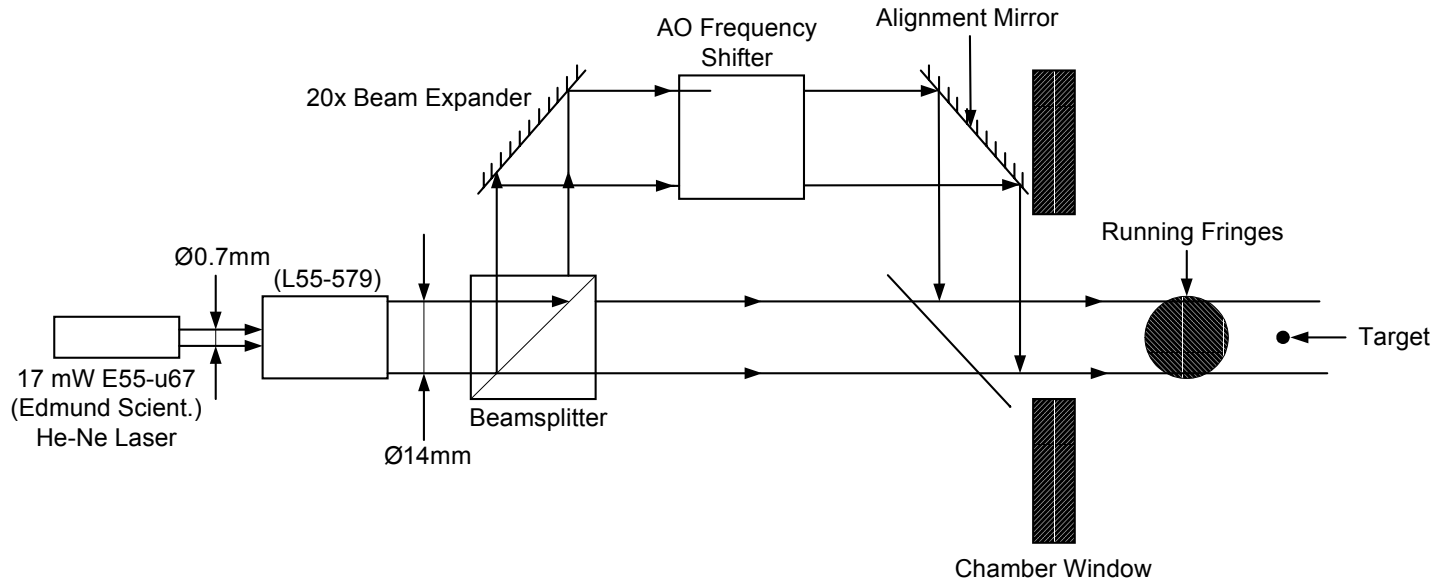

$$s(y, t) = I_0 \cdot e^{2\pi j f t} \quad \text{and} \quad (6)$$

$$s_2(y, t) = I_0 e^{\left\{ \alpha \pi j (f + \Omega) t + \frac{2\pi j \alpha y}{\lambda} \right\}} \quad (7)$$

$$I(Y) = 2I_0 \left\{ 1 + \cos \left[ \frac{2\pi}{\lambda} \alpha Y + 2\pi \Omega t \right] \right\} \quad (8)$$

# Tracking electronics

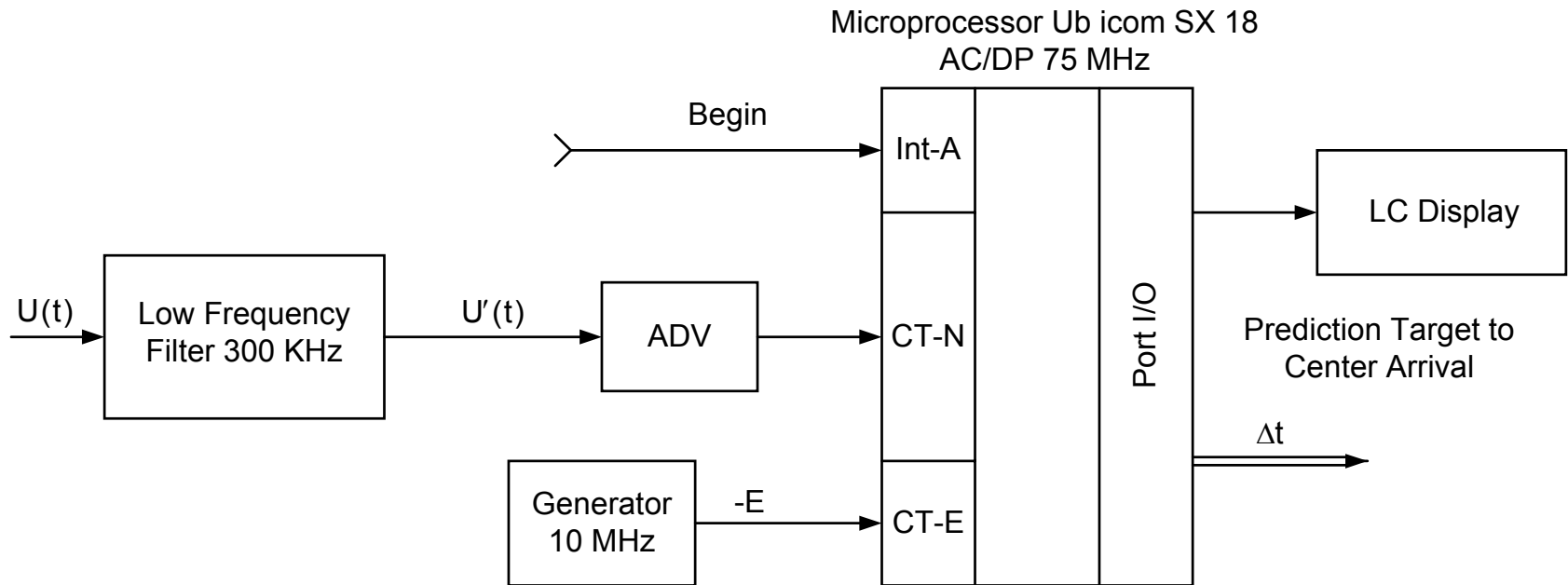

$$\Delta t = (R - S) / \left( \frac{s}{t} \right) \quad (9)$$

# *Adaptive detector for video signals including a time diagram*

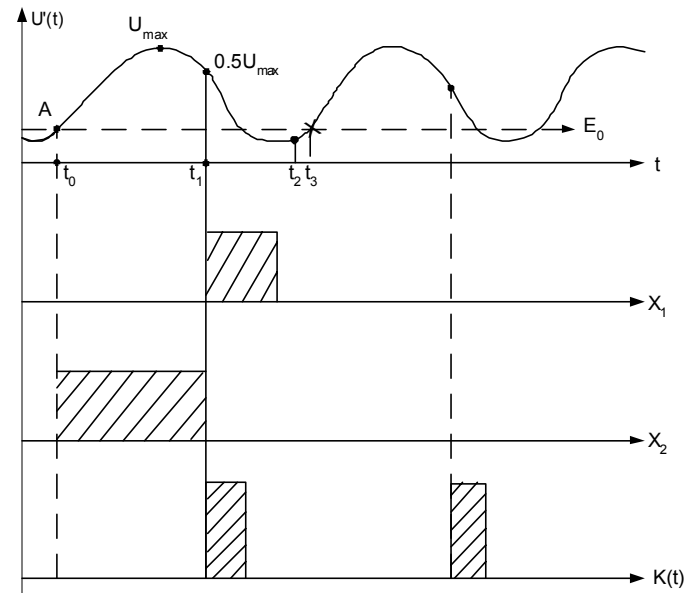
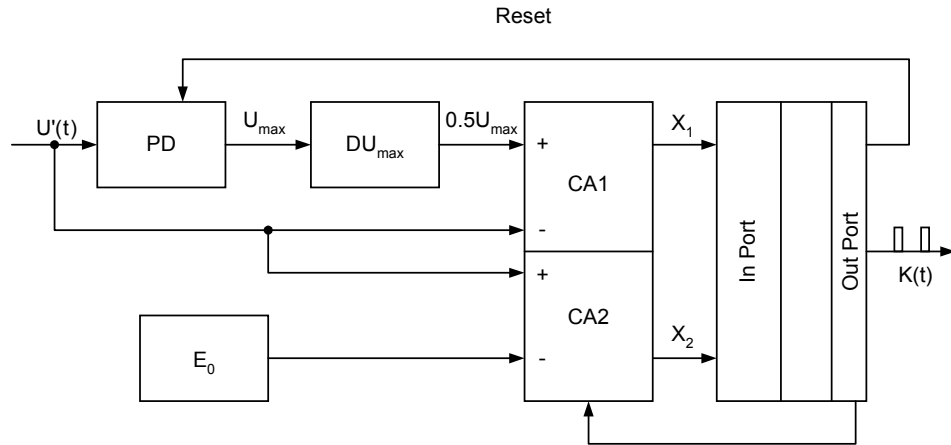

# *Output from Y tracking electronics*

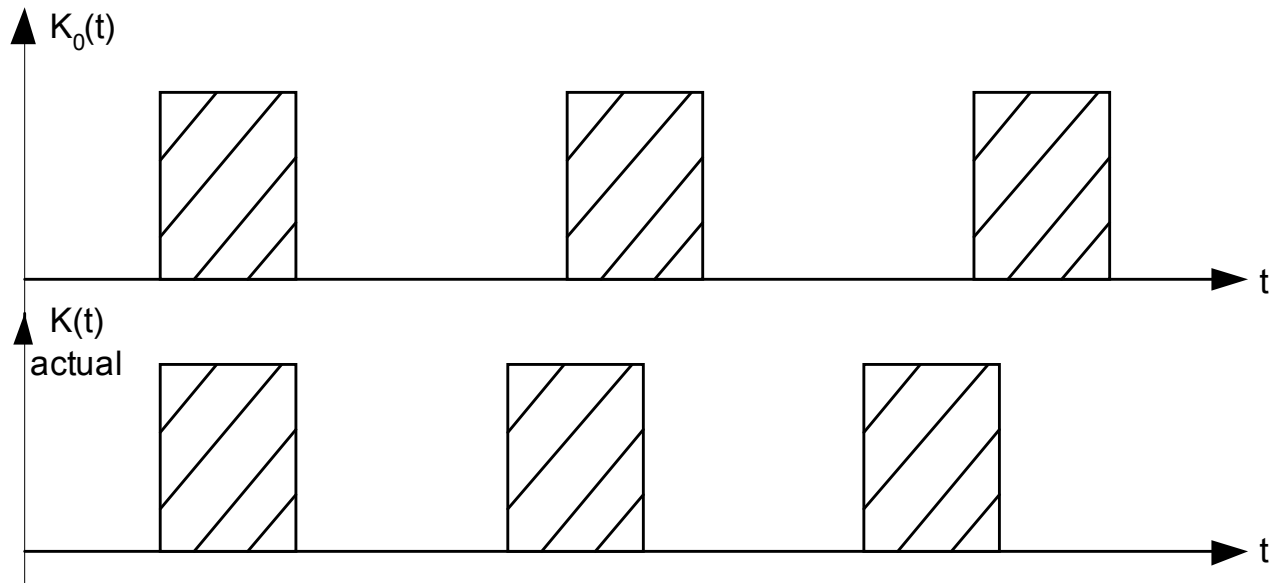

# *Project development schedule*

1. In 3 months completion of y, z interferometer design.
2. In 9 months completion of manufacturing of tracking system including tracking electronics.
3. In 12 months testing of ITTS, modification (if necessary), and integration into the GA system.